

# ABACOA-A REPLAT OF TRACTS GF1 AND GF2

A REPLAT OF ALL OF TRACTS GF1 AND GF2 OF ABACOA PLAT NO. 1, AS RECORDED IN PLAT BOOK 78, PAGES 145 THROUGH 163, INCLUSIVE, LYING IN SECTION 23, TOWNSHIP 41 SOUTH, RANGE 42 EAST, TOWN OF JUPITER, PALM BEACH COUNTY, FLORIDA

THIS INSTRUMENT PREPARED BY JAMES E. PARK, P.S.M.  
 WILLIAMS, HATFIELD & STONER, INC. - ENGINEERS PLANNERS SURVEYORS  
 1901 SOUTH CONGRESS AVENUE, SUITE 150, BOYNTON BEACH, FLORIDA 33426

MARCH, 1999

SHEET 6 OF 7

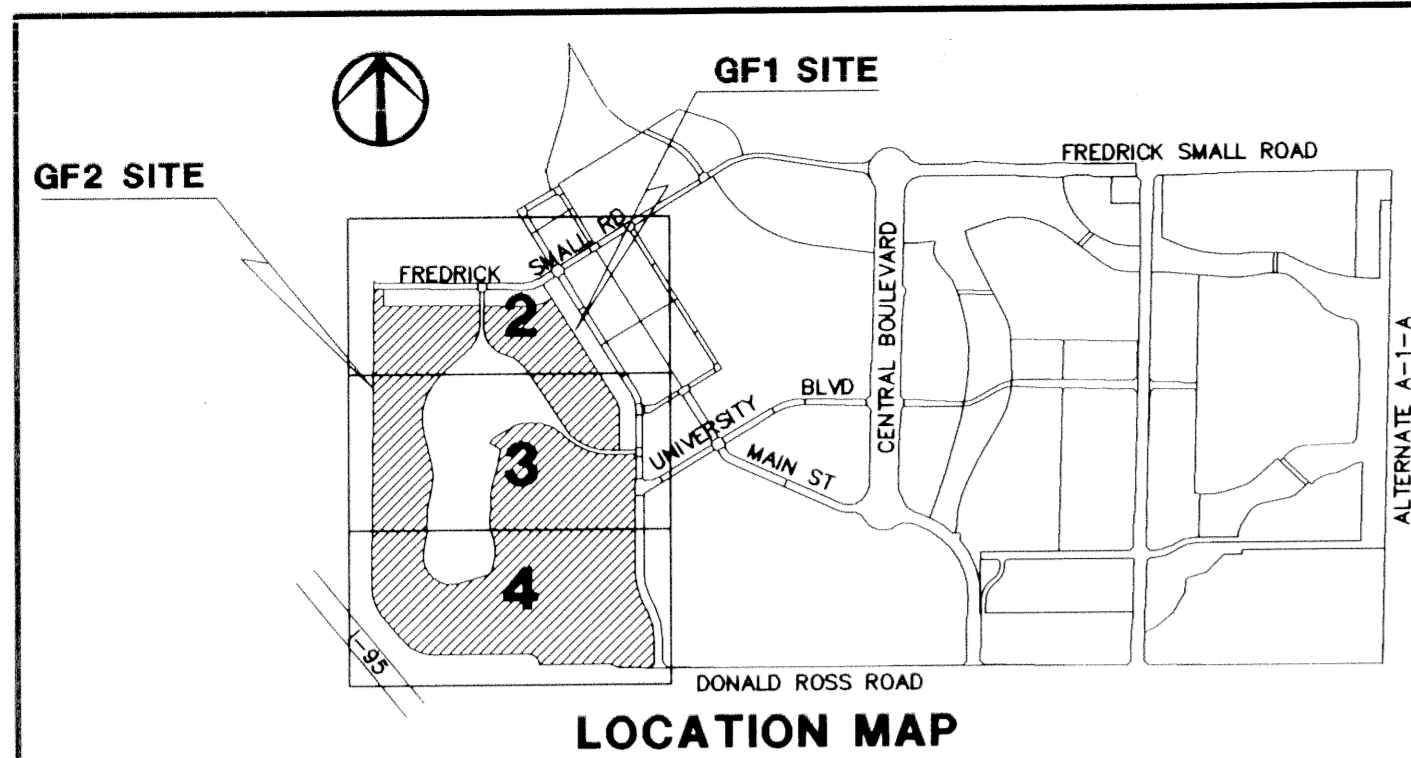

### TRACT F

NO.	CENTRAL ANGLE	RADIUS	LENGTH	BEARING	DISTANCE
1				S89°55'47"W	6.04'
2	19°17'23"	200.00'	67.33'		
3				N70°46'50"W	61.76'
4	19°17'23"	60.00'	20.20'		
5				S89°55'47"W	675.26'
6	59°50'50"	60.00'	62.67'		
7	59°50'50"	130.00'	135.79'		
8				S89°53'17"W	16.23'
9	40°22'36"	200.00'	140.94'		
10	23°54'20"	400.00'	166.89'		
11	31°08'45"	120.00'	65.23'		
11A				S42°29'42"W	6.16'
12	80°51'48"	24.42'	34.46'		
13				S78°21'10"W	98.05'
14	64°29'36"	60.00'	67.54'		
15				S37°09'14"E	113.33'
16	52°54'59"	100.00'	92.36'		
17				N89°55'47"E	325.77'
18	15°21'12"	400.00'	107.19'		
19	38°10'26"	400.00'	266.50'		
20				S67°14'59"E	150.39'
21	64°16'15"	133.00'	149.19'		
22	12°32'57"	65.00'	140.16'		
23	229°08'30"	73.00'	291.95'		
24	135°06'25"	70.00'	165.06'		
25	96°48'33"	50.00'	84.48'		
26				N18°48'56"W	75.57'
27	28°12'10"	100.00'	49.22'		
28				N47°01'06"W	132.09'
29	40°08'01"	100.00'	70.05'		
30				N06°53'05"W	207.54'
31	16°17'53"	100.00'	28.45'		
32	42°35'15"	193.00'	143.46'		
33	47°07'14"	150.00'	123.36'		
34	36°22'23"	230.00'	146.01'		
35	27°05'24"	200.00'	94.56'		
36	75°25'48"	239.00'	314.65'		
37	123°00'11"	40.00'	85.87'		
38				S00°00'00"E	626.54'
39	25°33'41"	715.00'	318.98'		
40				S25°33'41"E	143.97'
41	25°33'41"	605.00'	269.91'		
42				S00°00'00"E	239.96'
43	98°27'37"	60.00'	103.11'		
44				N81°32'23"W	67.31'
45	08°31'50"	200.00'	29.78'		
46				S89°55'47"W	142.15'

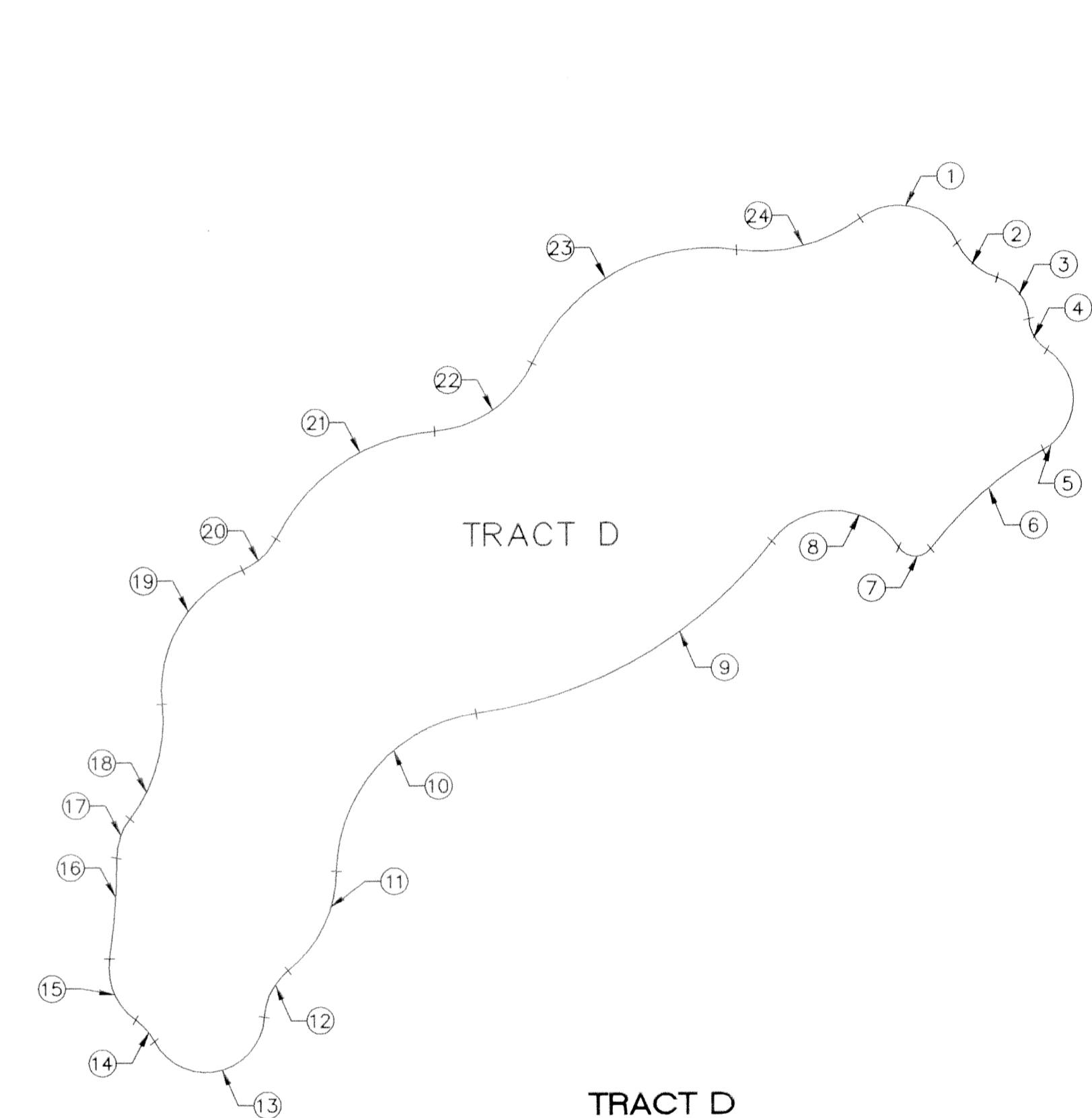
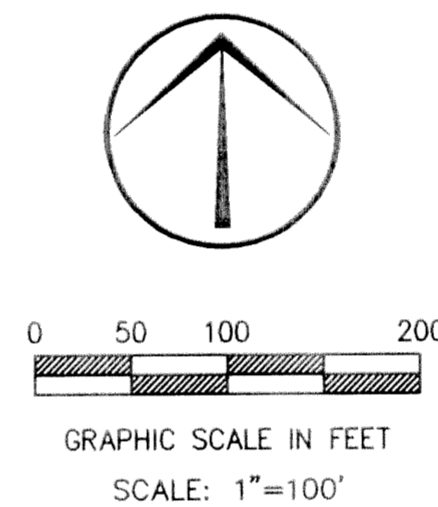
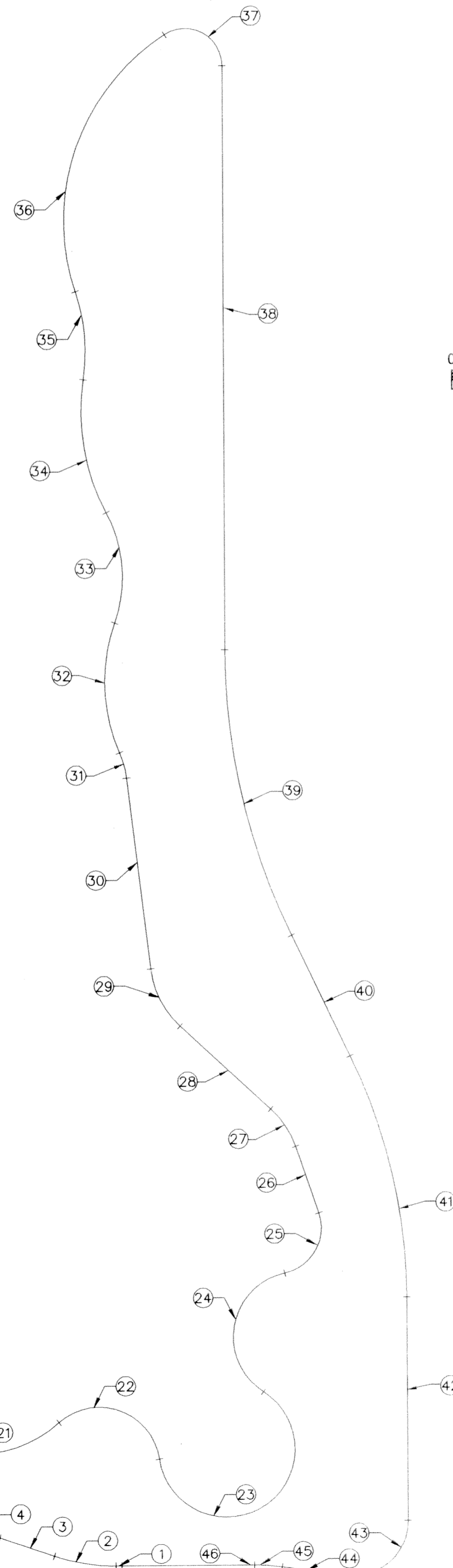

### TRACT D

NO.	CENTRAL ANGLE	RADIUS	LENGTH
1	101°21'04"	50.00'	88.45'
2	48°04'42"	50.00'	41.96'
3	70°25'11"	35.00'	43.02'
4	54°28'14"	30.00'	28.52'
5	118°07'00"	45.00'	92.77'
6	23°39'12"	280.00'	115.59'
7	110°22'30"	15.00'	28.90'
8	109°53'53"	60.00'	115.09'
9	44°13'43"	350.00'	270.18'
10	81°45'13"	125.00'	178.36'
11	50°50'35"	100.00'	88.74'
12	48°13'35"	50.00'	42.09'
13	149°06'13"	45.00'	117.11'
14	25°57'49"	50.00'	22.66'
15	62°20'54"	50.00'	54.41'
16	09°01'05"	500.00'	78.70'
17	37°53'08"	50.00'	33.06'
18	43°25'40"	125.00'	94.74'
19	74°12'54"	100.00'	129.53'
20	41°10'04"	50.00'	35.93'
21	58°46'09"	150.00'	153.86'
22	61°23'10"	90.00'	96.43'
23	73°48'09"	150.00'	193.21'
24	44°24'54"	130.00'	100.77'

